

RV Coffee Table
all material 3/4" thick

2-3/4 x 17-1/2

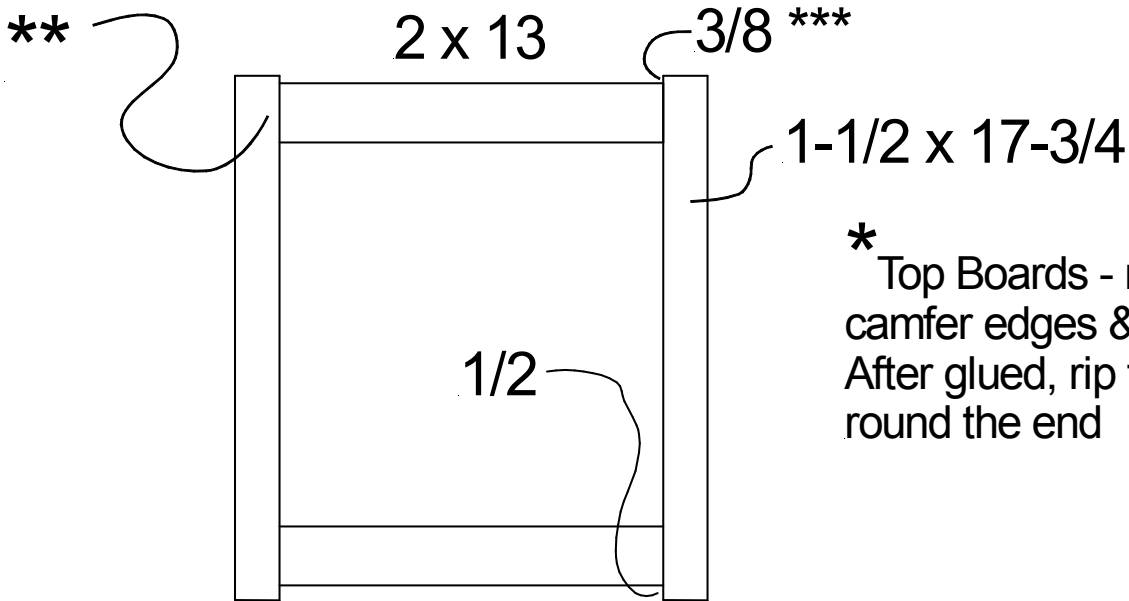
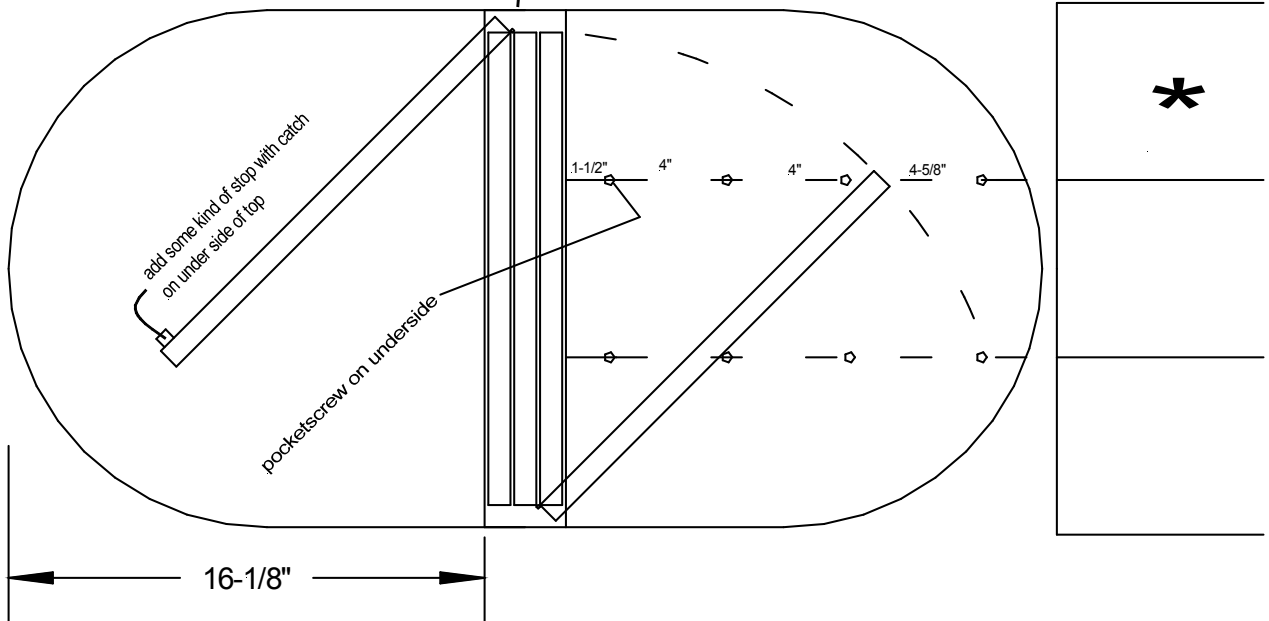

* Top Boards - rip 6" wide, camfer edges & glue panels. After glued, rip to 17.5" and round the end

** Consider camfer on edges so that the edge alignment is not as critical

*** Center frame can be flush at the top for more surface contact with center board on top. Others need 3/8 to clear hinges.